



CHARACTERISTICS

ENCODER TYPE	Hollow shaft encoder (blind end)
SMD - TECHNOLOGY	Strong compact electronics
HIGH IP-RATING	Std. IP 65
LOW CURRENT CONSUMPTION	To be connected directly to PLC'S and counters
SHORT CIRCUIT PROTECTION	Thermal shut down at 155°C
WIDE SUPPLY RANGE	Min. 4,5V to max. 30V
STRONG MEC. CONSTRUCTION	Based on 2 precision ball bearings, for harsh industrial environments

ELECTRICAL SPECIFICATIONS

At +25°C	
Output waveform	Incremental (A, B, Z and inverted)
Zero or index pulse	(Z) one pr./rev.
Output	Ttempole (TP)
Supply-voltage (Vin)	Min 4,5V to Max. 30V * Reverse polarity protection
Current (no load)	Max. 45 mA
Max. load pr. output	30 mA - (Shortcircuit protected)*
V out low	Max. 500 mV @ Iout low =10 mA
Operating temp.	- 40°C to + 85°C
Storage temp.	- 40°C to + 85°C
Max. pulse frequency	300 kHz *
V out high	Min. (Vin -0,6) @ I = -10mA Min. (Vin -1,3) @ I = -25mA
Cable data	8-leads (0,14 mm ²)pairtwisted/shielded
Output signals	Normal (Standard), Inverted, Differential (RS-422A compatible @ 5V)
Certified acc. to	EN 50081-1 and EN 50082-2
* = It is not recommended to combine max. value for all 3 parameters	

MECHANICAL SPECIFICATIONS

Weight	About 120 g
Materials : Housing	Aluminum
Shaft	Brass
Bearings	Lifetime lubricated ball bearings
H.-Shaft dimensions	ø6 mm ø8 mm
H.-Shaft loads	Axial max. 20 N Radial max. 20 N
Max. rev.	12,000 rev./min.
IP-rating	Standard IP 65
Start torque	< 0,01 Nm at 25°C
Mass moment of inertia	4 gcm ²
Max. shock	100 G/11 ms
Bump	10 G - 16 ms (1000 x 3 axis)
Vibration	(10 - 2000 Hz)/10 G

OUTPUT CIRCUIT

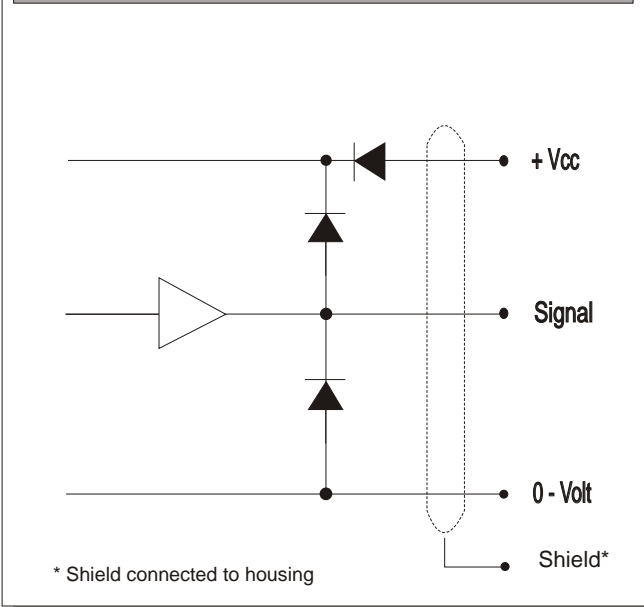

MECHANICAL DIMENSIONS

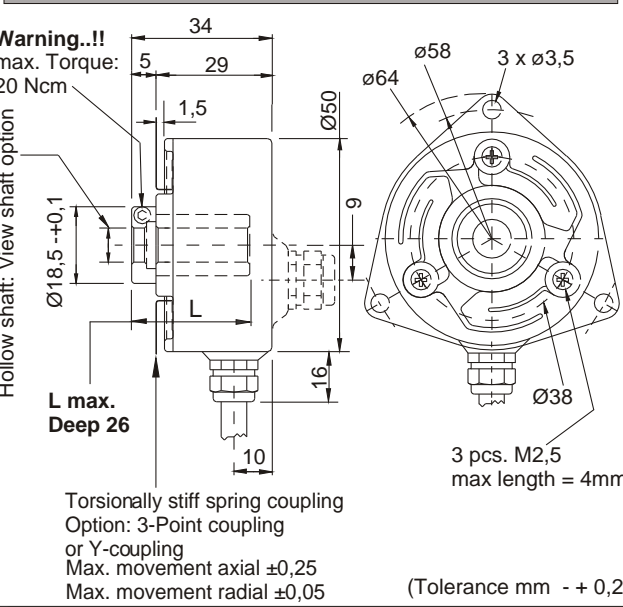

OUTPUT WAVEFORM

 Rotation: Clockwise (cw) from shaftside

(inv = inverted channels)

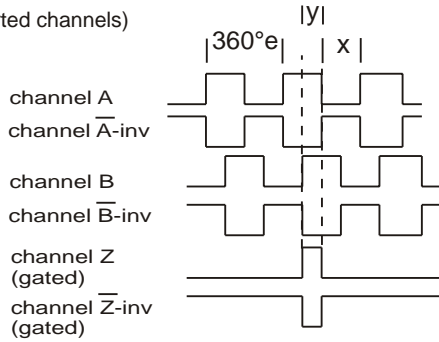

$X = 180^\circ \pm 36^\circ$ and $Y = 90^\circ \pm 18^\circ$
Z puls: Gated with A and B (standard)

Options: TTL or HTL compatible. Open Collector NPN or PNP
Gated Z-puls or none-gated Z-puls.
View more Output options in section 15 - page 1

ORDERING CODES

	Options	Ordering codes
Pulses pr. rev.:	No. of pulses	XXXXX
Output signal:	Normal, TP-Standard, A, B, Z (3 channel)	N
	TP-Differential: A, B, Z and A-inv, B-inv, Z-inv (6 channel)	D
	Line driver OL 7272 for extra long cable, up to 100 meters (Differential)	M
Shaft dimensions (Max deep 26 mm)	ø6 mm (tolerance G7)	06
	ø8 mm (tolerance G7)	08
IP-rating:	IP 65	65
Length of cable:	Standard 1 meter	01
	No. of meters	XX
Cable take out: (or connector)	Back (Axial)	B
	Side (Radial)	S
Anti rotation Spring coupling:	View Section 15 page 1 to 8	
Connector:	Coninvers Connector View Section 20 page 6	

CONNECTIONS

Color code	Standard
Pink	Ch. A
Grey*	Ch. A Gnd
Green	Ch. B
Yellow*	Ch. B Gnd
White	Ch. Z
Brown*	Ch. Z Gnd
Red	Vcc
Blue*	Gnd

*Blue, grey, yellow and brown are internal connected

Color code	Differential
Pink	Ch. A
Grey	Ch. A inv.
Green	Ch. B
Yellow	Ch. B inv.
White	Ch. Z
Brown	Ch. Z inv.
Red	Vcc
Blue	Gnd

PULSES/REV.

1	32	150	600	2048
2	36	180	635	2500
5	40	200	720	3000
6	50	250	800	3600
8	60	300	1000	4000
10	64	360	1024	4096
15	75	400	1131	5000
16	80	455	1250	9000
20	90	500	1500	12500
25	100	512	2000	
30	125			

Advanced Output Options:

Options	Ordering codes
Normal Open Collector NPN	NON
Differential Open Collector NPN	DON
Normal Open Collector PNP	NOP
Differential Open collector PNP	DOP

To order, replace with

Output signal Output signal

2RHF

Pulses

Output signal

H.-Shaft

65

IP-rating

Length of cable

Cable take out

Anti Rotation Spring Coupling

Accessories Order Number