



CHARACTERISTICS

ENCODER TYPE	Hollow shaft absolute singleturn encoder
TECHNOLOGY	Magnetic Resistance
SMD - TECHNOLOGY	Strong compact electronics
IP-RATING	Std. IP 64 (option: Ribbon cable + IDC-Connector = IP 50)
LOW CURRENT CONSUMPTION	To be connected directly to PLCs
SUPPLY RANGE	5V ± 10% or 3,3V ± 10%
STRONG CONSTRUCTION	Based on 2 precision ball bearings, for industrial environments

ELECTRICAL SPECIFICATIONS

At 25°C			
Output	SSI		
Supply-voltage (V+)	5V ± 10% or 3,3V ± 10%		
Current (no load)	max. 25mA		
Max. Load pr. output	4mA @ 5V (short circuit protection)		
Operating temp.	-40°C ... +100°C		
Storage temp.	-55°C ... +100°C		
Humidity non-cond.	5% ... 85%		
Cable data	5 leads (0,14mm ²), shielded		
Resolution	10 bit	12 bit ^⑤ (slow mode)	12 bit ^⑤ (fast mode)
electr. permissible speed (see note ②!) @ 512 pulses/rev.	1172 rpm	306 rpm	1121 rpm
@ 1024 pulses/rev.	586 rpm	153 rpm	610 rpm
@ 4096 pulses/rev.	---	38 rpm	153 rpm
System propagation delay (calculation time)	65 µs	384 µs	96 µs
Transition noise	0,12° rms	0,03° rms	0,06° rms
Precision	0,5°±LSB	0,5°±LSB	0,5°±LSB

MECHANICAL SPECIFICATIONS

Weight	approx. 75 g
Materials: Housing	Electroplated steel and brass
Hollow shaft	Stainless steel
Fixing Clamp	Brass
Bearings	Lifetime lubricated ball-bearings
H-shaft dimensions	ø2mm, ø3mm, ø4mm, ø5mm ø6mm, ø1/4"
H-shaft loads	axial max. 20N radial max. 20N
Mech. max. speed	10.000 rev./min (see notes ② and ③)
IP-rating	IP 64 (IP 50, with ribbon cable)
Start torque	<0,005 Nm at 25°C
Mass moment of inertia	<1,3 g·cm ²
Max. shock	10 g / 11ms
Bump	10 g - 16ms (1000 x 3 axis)
Vibration	(10 - 2000 Hz) / 10 g



Notes:



- The absolute angular position is always set to the highest resolution; regardless of rotational speed or the number of positions to be read out.
- The absolute angular position is sampled at a fixed rate. This allows a maximum speed as shown in the electrical specifications without missing positions.
- By increasing the rotational speed, the number of issued absolute angular positions will decrease.
- Data D11:D0 resp. D9:D0 is valid when the status bits have the following configurations:

OCF	COF	LIN	MagINC	MagDEC	Parity
			0	0	even
1	0	0	0	1	checksum of bits 1 to 15
			1	0	
- Make sure you give us information about the 12 bit speed mode in your order:
"slow mode" - slow speed applications;
"fast mode" - for applications with higher speeds.

MECHANICAL DIMENSIONS

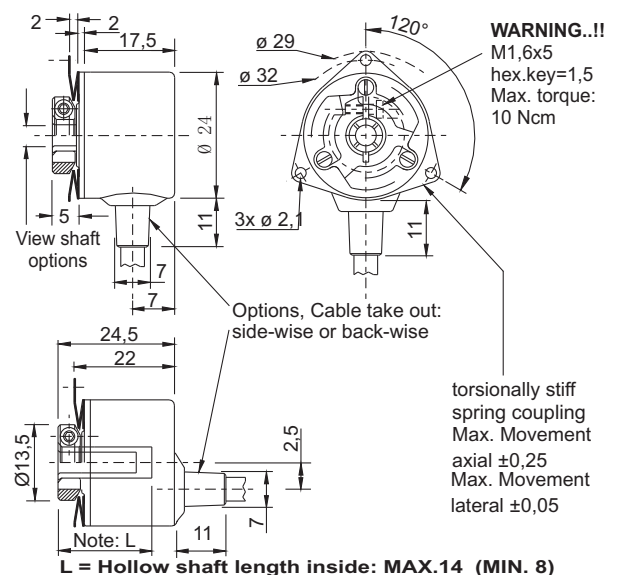

SERIAL SSI-INTERFACE

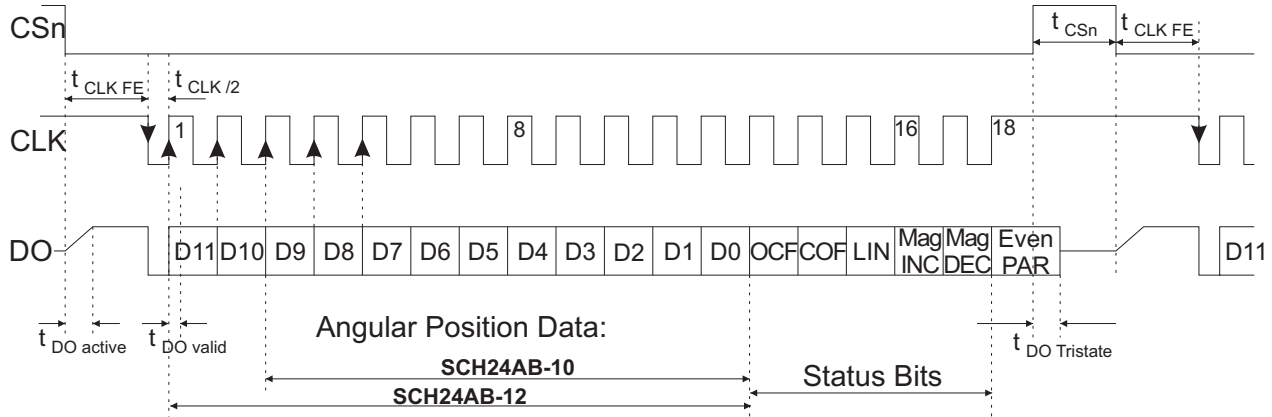

SSI SYMBOL DECLARATION

D11 ... D0: absolute angular position data (D11: MSB @ 12bit res.; D9: MSB @10 bit res.; D0: LSB).
OCF (Offset Compensation Finished): logic high indicates the startup to be completed and data to be valid.
COF (Cordic Overflow): logic high indicates invalid data on bits D11:D0 resp. D9:D0. The absolute output maintains the last valid angular value.
LIN (Linearity Alarm): logic high indicates critical output linearity on the input field. When bit is set, data bits may still be used but can contain invalid data.
MagINC (Magnitude Increase): becomes high when magnetic field is increasing (pushing the magnet towards IC).
MagDEC (Magnitude Decrease): becomes high when magnetic field is decreasing (pulling the magnet away from IC).
Even PAR (Even Parity): for transmission error detection of bits 1 to 15.

SSI-INTERFACE TIMETABLE

$t_{CLK FE}$ = min. 500 ns	First data shifted to output register
$t_{CLK / 2}$ = min. 500 ns	Start of data output
$t_{DO active}$ = max. 100 ns	Data output activated, logic high
$t_{DO valid}$ = max. 375 ns	Data output valid
t_{CSn} = min. 500 ns	Pulse width of CSn
$t_{DO Tristate}$ = max. 100 ns	Data output tristate

STANDARD CABLE CONNECTIONS

Color-code	Output
white	GND, 0 Volt
brown	V+
green	CSn
yellow	CLK
gray	DO

ORDERING CODES

Resolution / elec. specification:	10 bit - 3,3V	10A
	10 bit - 5,0V	10B
	12 bit - 3,3V - Fast mode	12E
	12 bit - 3,3V - Slow mode	12F
	12 bit - 5,0V - Fast mode	12G
	12 bit - 5,0V - Slow mode	12H
H.-shaft dimensions:	ø2mm	02
	ø3mm	03
	ø4mm	04
	ø5mm	05
	ø6mm	06
	ø1/4"	1/4
IP-rating:	IP 64	64
Length of cable:	Standard 1 meter	01
	No. of meters	XX
Cable take out:	Side	S
	Back	B
OPTION:		
Cable type:	Ribbon cable + IDC (HP-compatible)	IDC
Ribbon cable length:	0,5meter	0,5
	1,0meter	1,0
	2,0meter	2,0

Option: IDC Connector with ribbon cable

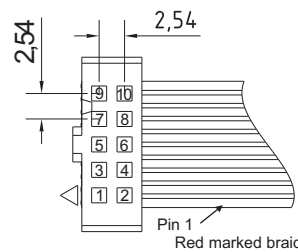

Pin no.	Diff.
1 (Red)	Do not connect!
2	CSn
3	Do
4	CLK
5	V+
6	GND, 0 Volt
7	Do not connect!
8	Do not connect!
9	Do not connect!
10	Do not connect!

See Section 20 - Page 10 for ribbon cable outline dimensions.

Note:
Mechanical outline for Encoder with IDC connector and ribbon cable

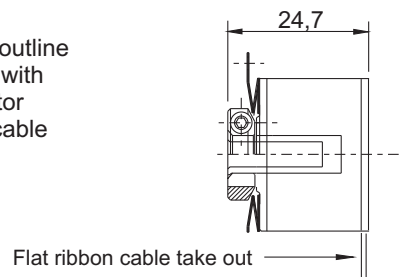

To order the standard version: **SCH24AB**

Resolution / electr. specification	H.-shaft	64	Cable length	Cable take out
------------------------------------	----------	----	--------------	----------------

- the version with ribbon cable: **SCH24AB**

Resolution / electr. specification	H.-shaft	50	Cable length	Cable type
------------------------------------	----------	----	--------------	------------